

NAVIGATOR



Pilot
REACHING NEW HEIGHTS

-  Merits Health Products, Inc
-  Pilotstairs
-  Pilot Stairlifts
-  MeritsUSA

mobility 
product award 2021

Let Pilot Navigate you to new heights with our custom built curve stairlift

BUILT TO LAST

Each track is 100% built to order utilizing a combination of advanced 3D tube bending technology and skillful craftsmanship. Our system reduces the number of joints in the rail resulting in a stronger track and a smooth, comfortable ride.



PRECISE FIT

As every staircase is different, each custom-built Navigator starts with a detailed survey using our easy to use, photo survey system. Most staircases can be surveyed in 30 minutes or less and we guarantee that the lift will fit perfectly.

The twin rail design fits close to the wall to leave more room on the staircase and with our steep start option, the track can take up as little as 11" at the lower landing.

STANDARD FEATURES

- Synchronous folding seat and footplate
- Smooth start and stop technology
- LED on carriage to illuminate your staircase
- Sleep mode preserves the batteries for up to 20 days when left off charge
- Diagnostic display
- Key switch



HEAVY DUTY OPTION WITH VOICE COMMAND

The HD option increases the weight capacity of the stairlift to 350lbs and is equipped with an LCD display to inform the user of the status of the lift.

Forget to leave the lift on charge? The Navigator HD with voice command will alert the user, an industry first!



OUTDOOR UNIT

The Navigator outdoor has been completely weatherized to withstand the elements.

Each unit is supplied with:

- 2 lockable, wall mounted boxes for the remotes
- A weatherproof charger box
- Weather resistant cover to protect the unit when not in use

Technical Specifications	
Weight capacity	265 lbs (350 lbs with HD option)
Motor	950W, 24VDC
Speed	20-fpm~ 6M/min
Drive Method	Rack & Pinion
Incline Limits	°0-52
Charger	115~230V AC, 50/60Hz
Battery	24VDC re-chargable batteries
Internal Arm Rest Width	16" - 20"
Seat to Footplate Height	18.8"
Remote Controls	2 RF remotes included
Compliance Standards	ASME A18.1/A17.5
Safety Sensors	5 safety sensors as standard
Safety Devices	Overtravel prevention, motor brake, key switch, retractable seat belt, armrest and swivel seat safety switches, OSG
Warranty	5 years on the motor gear box 2 years on components

COLOR OPTIONS

A choice of track and upholstery options to complement your décor.

SEAT COLORS



RAIL COLORS

RAL 1013 Oyster White	RAL 8024 Beige Brown
RAL 9010 Pure white	RAL 7044 Silk Grey

DIMENSIONS

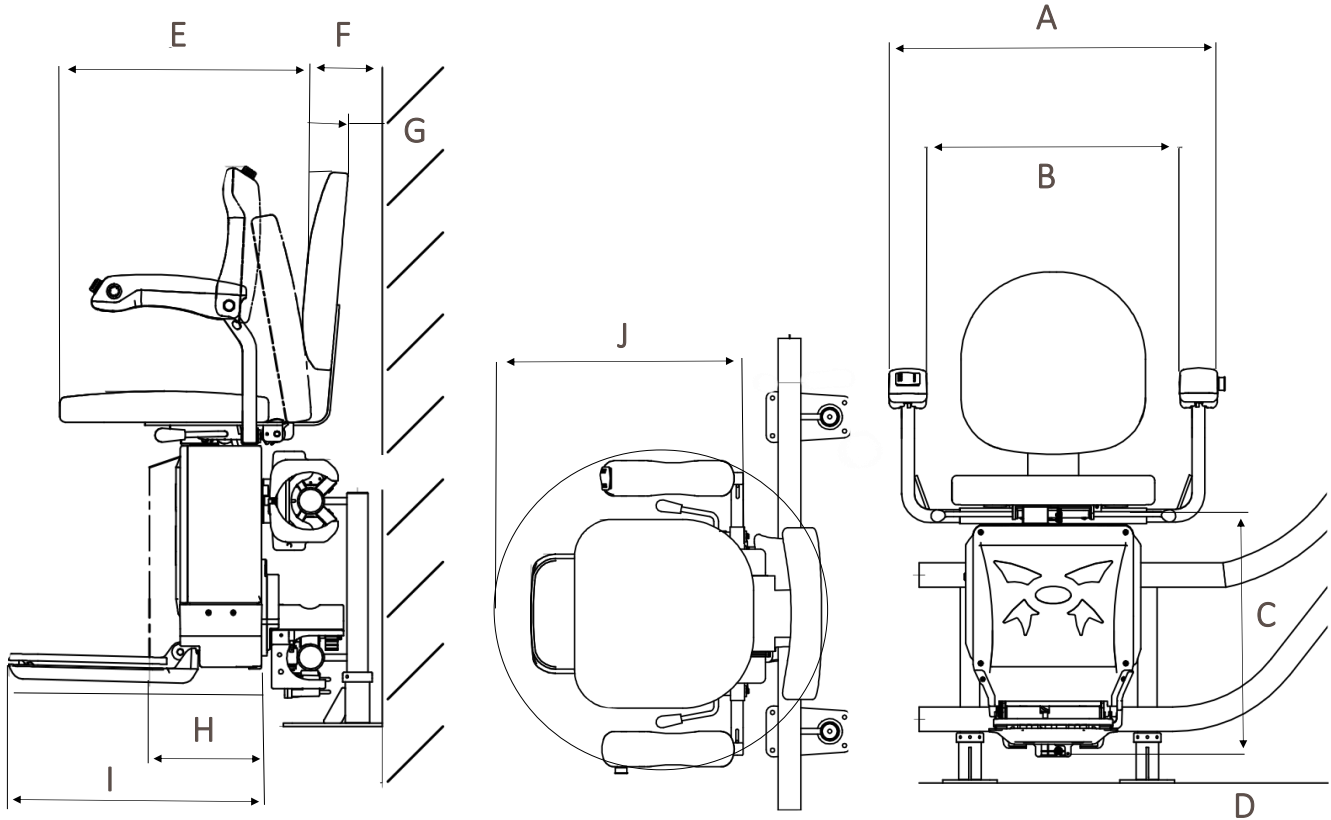

Front view	Inches
A - External armrest width	22 to 26
B - Internal armrest width	16 to 20
C - Seat to footrest height	18.8
D - Footrest to floor	3.5
Side view and top view	Inches
E - Seat Depth	16.36
F - Wall to inside of seat	4.6
G - Wall to seat back	2.5
H - Folded width	16.7
I - Unfolded width	26.8
J - Swivel radius	25.4
Track intrusion	6.1

Please note, all dimensions that are measured from the wall are the minimum that can be achieved. Adjustments to these dimensions may be necessary to account for any constructions that are present .