

Pilot

AVIATOR

E603 STRAIGHT STAIRLIFT



©Merits Health Products, Inc.
4245 Evans Ave | Fort Myers, FL 33901

WHY CHOOSE PILOT ?

At Pilot, we understand the challenges a staircase can present and we are passionate about helping people maintain their freedom and independence in the home they love. The Pilot Aviator, for straight staircases, offers a great combination of style, safety and comfort.

VERSATILITY

- The universal design allows the lift to be installed on the left or right side of the stairs
- Armrest width, seat height and toggle position are fully adjustable to meet the user's needs
- 2 position swivel seat for safe transfers on and off the lift



FUNCTIONALITY

- Extra long charging stations make charging the powerful 9Ah batteries easy
- In the event of a power outage, the Aviator's automatic sleep mode will preserve the batteries for up to 20 days!
- Equipped with a battery test point, diagnostic display and easy access panels for fast, accurate services

SAFETY IS THE STANDARD

- 5 directional safety sensors
- Retractable seat belt
- Armrest position sensors
- Seat position sensor
- Over speed governor
- Electro mechanical brake
- Key switch



AUTOMATIC HINGED RAIL

Pilot's auto folding rail option keeps the walkways clear when not in use

The fully automatic system ensures that the rail is always in the right position, making the operation for the user a breeze



OUTDOOR UNIT

The Aviator outdoor has been completely weatherized to withstand the elements.

Each unit is supplied with:

- 2 lockable, wall mounted boxes for the remotes
- A weatherproof charger box
- Weather resistant cover to protect the unit when not in use

Technical Specifications

Weight capacity	350 lbs (300 lbs with hinge option)
Motor	950W, 24VDC
Speed	20-fpm ~ 6M/min
minDrive Method	Rack & Pinion
Incline Limits	25° - 55°
Charger	115~230V AC, 50/60Hz
Battery	24VDC re-chargable batteries
Internal Arm Rest Width	16" - 20"
Seat to Footplate Height	18.8"
Remote Controls	2 infrared remotes included
Compliance Standards	ASME A18.1/A17.5
Safety Sensors	5 safety sensors as standard
Safety Devices	Overtravel prevention, motor brake, key switch, retractable seat belt, armrest and swivel seat safety switches, OSG
Warranty	5 years on the motor gear box 2 years on components

OPTIONS

- Hinge Rail
- Extended Footplate (2")
- Extended Seat Post (2")
- Extended Stair Brackets (6")
- DC Charger Extension (8ft)

Available in 4 upholstery colors



Red



Beige



Dark Brown



Light Brown

DIMENSIONS

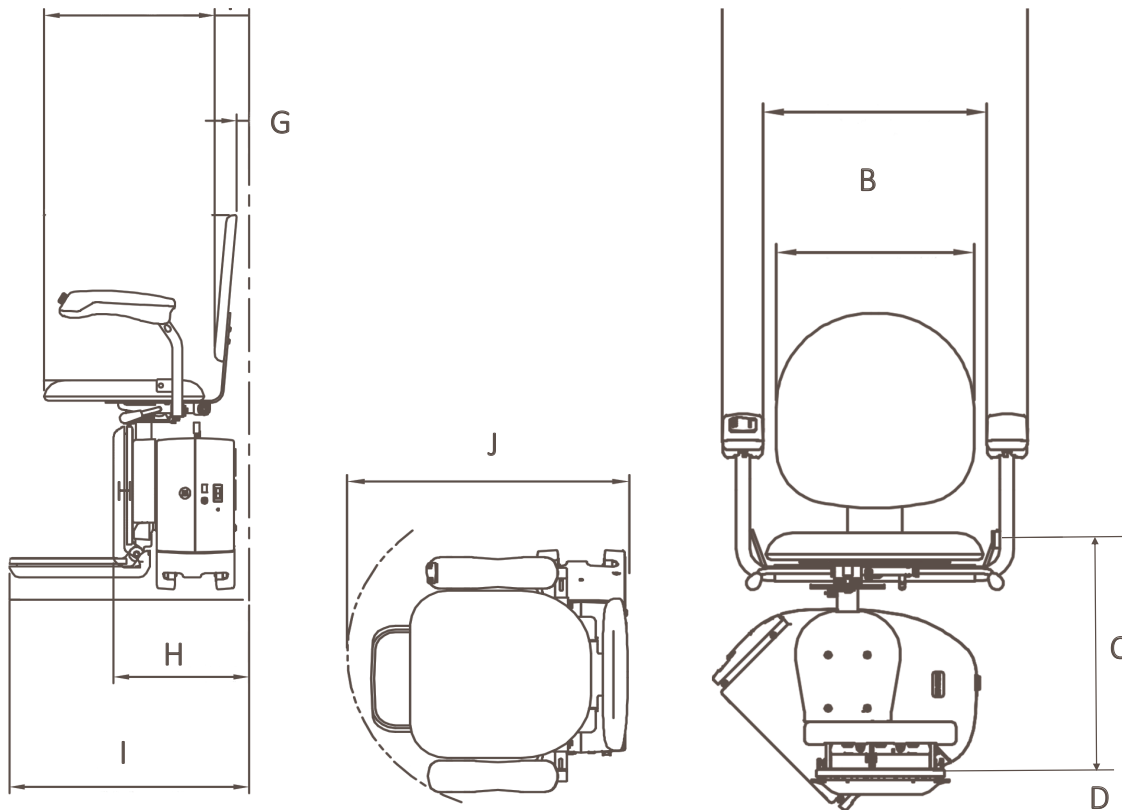



Front view	Inches
A - External armrest width	22 to 26
B - Internal armrest width	16 to 20
C - Seat to footrest height	17 to 20
D - Footrest to floor	4
Side view and top view	Inches
E - Seat Depth	16.36
F - Wall to inside of seat	3.3
G - Wall to seat back	1.18
H - Folded width	13
I - Unfolded width	23
J - Swivel radius	24
Track intrusion	7.88

Please note, all dimensions that are measured from the wall are the minimum that can be achieved. Adjustments to these dimensions may be necessary to account for any constructions that are present.

Follow Us To Learn More:

YouTube  @MeritsUSA4245
 Instagram  Merits Health USA

LinkedIn  Merits Health Products, Inc.
 Facebook  Merits Health Products, Inc.