

Owner's Manual



► Power Chair P331

Table of Contents

Introduction	
Indications For Use	2
Quantity of Contents	2
Device Description	2
Safety Instructions	
Practice Before Operating	4
Safety Considerations	6
Occupied Motor Vehicle Transport	7
EMC	10
Driving Outdoors	12
Driving on Various Terrains	14
Familiarize Yourself With Your Powerbase Wheelchair	
Feature Diagram	16
Specification	17
Terminology	17
Operating Your Powerbase Wheelchair	
Manual Freewheel Levers	20
Batteries and Charging	21
Care and Maintenance	23
IEC Symbols	32
Warranty	
Troubleshooting Tips	34

Welcome aboard your new powerbase wheelchair, and thank you for choosing our product. Please read this manual carefully, and follow all instructions before attempting to operate your powerbase wheelchair for the first time. If there is anything in this manual that you do not understand, or if you require additional assistance for setting up your powerbase wheelchair, please contact your local dealer.

This latest model is designed for specific practical user needs, combining solid, rugged construction, and modern high-tech electronics, to enhance safety and performance.

With a state-of-the-art, programmable electronic control system, your powerbase wheelchair can be programmed and adjusted within a given range of its performance characteristics, to suit your individual needs. The controller is set up at the factory to give the powerbase wheelchair nominal operating performance characteristics.

After becoming familiar with the basic operation of the powerbase wheelchair, you may wish to customize the settings to fit your own personal preferences. A wide range of customization options can be adjusted such as acceleration, deceleration, maximum speed, turning speed, safety controls, better maneuverability of the joystick, and so on. Contact your local dealer for advice on additional equipment you may need.

Having your powerbase wheelchair checked regularly by your local dealer is the best way to ensure smooth operation, and safety.

This manual provides users practical tips and information on safety issues, operation, and maintenance. Please read it very carefully to ensure your maximum enjoyment and to fully benefit from your independence and mobility.

Whenever special advice or attention is needed, please do not hesitate to contact your local dealer, who has the tools and know-how to provide expert servicing for your powerbase wheelchair.

Your satisfaction and opinions are highly valued by both your local dealer and our company. Please be sure to fill out the enclosed guarantee form, and return it to your local dealer. The information is necessary for providing you with the best service, and to be sure all of your needs are met.

■ Indications For Use

The Merits Model R series Positioning System for Powered Wheelchair is intended for people using a powered wheelchair and requiring positional change. Its intended function and use is to aid in the pressure relief to persons confined to a powered wheelchair, by way of tilt and reclining seat back.



Cautions

Federal law restricts this device to sale by or on the order of a physician. For applicable countries.

■ Quantity of Contents

The device is divided into two packages: Base Unit (P331) and Seating System (R series Positioning System). The quantity of contents are as following:
Base Unit Package

Item	Component	Quantity	Note(Sold separately)
1	Power Base	1	
2	Joystick	1	V
3	Charger	1	V
4	Power cord	1	V
5	Owner's manual	1	
6	Battery connecting wire	2	V
7	Tool kit	1	V

Seating System Package

Item	Component	Quantity	Note(Sold separately)
1	Seat	1	
2	Headrest	1	V
3	Cushion	1	V
4	Back Cushion	1	V
5	Owner's manual	1	
6	Footplate	1	V

■ Device Description

The R Series Positioning System for Powered Wheelchair is designed for use with power wheelchairs. The R Series Positioning System for Powered Wheelchair use the Merits Model P331 Power Wheelchair as the base unit for the tilting, reclining and elevating System. The Positioning

System and base unit is to be sold together. Model P331 Powered Wheelchair is battery powered, center wheel motor driven and is controlled by the PG power wheelchair controller. The user interface is a joystick. P331 is powered by two 12 VDC 55ah batteries. The batteries are charged by 5A off-board charger connect with 3-pin Microphone Connector to charging socket on joystick. The approximate driving range on fully charged batteries is up to 24.7km(15.3mi). The chair frame is a riveted nut and welded steel construction and includes two center drive wheels with drive units (including motor, gear, brake), batteries and front and rear pivoting casters. Depending on users needs, the joystick motor control is mounted to the left or right armrest. When the user activates the joystick, the controller receives a signal to release the brakes. With the brakes released, the wheelchair is allowed to move in the direction the joystick is actuated. When the user releases the joystick, the chair slows to a stop and the brakes are automatically re-engaged. The solenoid electromechanical brakes allow the user stop by letting go of the joystick.

The intended function of the R Series Positioning System for Powered Wheelchair is to aid in the pressure relief of persons confined to a wheelchair, by providing a method of tilting the seat and reclining the seat back.

The R series Positioning System consists of tilt, recline and shear reduction seat modules. The tilting and reclining systems are separate modules and are independent of each other. As such, they will be offered as either a complete tilt/recline system, or as a separate tilt system or reclining system depending upon the user' needs.

The tilting and reclining systems are actuated by 24V DC motorized linear actuator. The tilt system include one motorized linear actuator (Manufacturer: Moteck / Model: FD60-24-F3-323) causes the seat frame to shift forward. This enhances stability since the center of gravity is kept substantially in place while the user is tilting.

The recline system include one motorized linear actuator (Manufacturer: Moteck / Model: FD-24-A4-278) change the position of the backrest with respect to the seat pan. The shear reduction module works with recline function to reduce the shear movement between the user and the backrest. The reclining system also includes a movable leg rest feature.

There two basic models included in the R Series Positioning System.

The upholstery of the device complies with EN 1021-1/-2:2006: Furniture: Assessment of the ignitability of upholstered furniture: Ignition source: Smouldering cigarette/ Match flame equivalent.

The device can be operated on dry, level surfaces composed of concrete, blacktop, or asphalt under normal driving conditions.

The Merits R Series Positioning System is substantially equivalent to the Motion Concepts TRx-CG power Positioning System (#K021264). Both products are battery power, motorized, seating systems designed for use with powered wheelchairs. Performance characteristics and drive mechanisms are similar and all have the same intended function and use which is to aid in the pressure relief of persons confined to a powered wheelchair, by providing a method of tilting the seat and reclining the seat back. Additional, they are all constructed from the same basic materials, have the same basic operational principles and all use DC batteries as their source of power.

Although there are some minor differences between R Series Positioning System and its predicate device, they raise no new issues of safety or effectiveness. Performance data demonstrate that the R Series Positioning System is safe. The non-clinical testing and the predicate comparisons demonstrate that any differences in their technological characteristics do no raise any new questions of safety or effectiveness.

Failure to follow these instructions may result in damage to the powerbase wheelchair or serious injury.

■ Practice Before Operating

Find an open area such as a park and have an assistant to help you practice until you have confidence operating this vehicle.

Make sure that the power is off before getting in or out of the seat. Set the speed control button according to your driving ability.

We recommend that you keep the speed control at the slowest position until you are familiar with the driving characteristics of this vehicle.

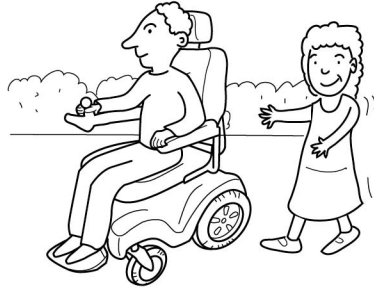

■ Refer to Controller System Operation manual



Getting familiar with this vehicle



SAFETY WARNING

YOUR AUTHORIZED DEALER, PROVIDER, THERAPIST(S), AND/OR OTHER HEALTHCARE PROFESSIONALS ARE RESPONSIBLE FOR DETERMINING YOUR REQUIREMENT FOR A SEAT BELT FOR SAFE OPERATION OF YOUR MOBILITY DEVICE. REQUIRING A SEAT BELT TO SAFELY OPERATE YOUR MOBILITY PRODUCT, MAKE SURE IT IS FASTENED SECURELY IN ORDER TO REDUCE THE POSSIBILITY OF A FALL FROM THE MOBILITY PRODUCT.



First, practice moving forward.
Be sure to set the speed to the lowest setting.



After becoming familiar with moving forward,
practice making "S" turns.



Once you are familiar with "S" turns, practice
moving in reverse. Note that at any speed
control setting, the vehicle moves more slowly in
reverse than forward

■ Safety Considerations

DO NOT do any of the following



NO!

Do not carry any passengers



NO!

Do not drive across a slope



NO!

Do not drink and drive
Consult your physician to
determine if your medications
impair your ability to control this
vehicle



NO!

Do not tow a trailer



NO!

Do not turn on or use hand-held personal
communication devices such as citizens band(CB)
radios and cellular phones

■ Occupied Motor Vehicle Transport

The power chair user should transfer into the vehicle seat and use the vehicle-installed restraint system if and whenever feasible. The power chair should then be stored and secured in the vehicle.

If it is found necessary at the user's discretion to secure a power chair to a vehicle, the vehicle must be equipped with a Wheelchair Tie-down and Occupant Restraint System that has been installed in accordance with the tie-down manufacturer's instructions. It is essential to use a complete Wheelchair Tie-down and Occupant Restraint System to secure the power chair to the vehicle and to provide the power chair occupant with a properly designed and tested safety restraint system. A restraint system with both pelvic and upper-torso belts must be used to protect the power chair occupant and minimize the likelihood of injury caused by contact with the vehicle during a crash or sudden braking.

Seat

The level of resistance to ignition of materials and assemblies: Materials are tested according to EN1021-1, -2(seat, armrests).

Electrical components

The level of resistance to ignition of materials and mains current are tested according to UL94-V0.

Note: The product comply with EN 12184 Class B standard.

Note: This product can be used for temperature -8°C~50°C on the hard ground environment.

Warnings

- **WARNING!** YOUR AUTHORIZED DEALER, PROVIDER, THERAPIST(S), AND/OR OTHER HEALTHCARE PROFESSIONALS ARE RESPONSIBLE FOR DETERMINING YOUR REQUIREMENT FOR A SEAT BELT FOR SAFE OPERATION OF YOUR MOBILITY DEVICE.
WARNING! YOU REQUIRE A SEAT BELT TO SAFELY OPERATE YOUR MOBILITY PRODUCT. MAKE SURE IT IS FASTENED SECURELY IN ORDER TO REDUCE THE POSSIBILITY OF A FALL FROM THE MOBILITY PRODUCT.
- **WARNING!** NEVER ATTEMPT TO GET ONTO OR OFF OF YOUR MOBILITY PRODUCT WITHOUT FIRST ENSURING THE UNIT IS POWERED OFF.
- **WARNING!** IF YOUR POWER CHAIR IS EQUIPPED WITH A POWER ELEVATING SEAT FUNCTION, PLEASE ENSURE THAT YOUR SEAT IS IN THE LOWEST POSITION BEFORE TRAVELLING A SLOPED INCLINE. DO NOT USE THIS LIFT FUNCTION WHILE TRAVELING UP/DOWN THE SLOPE.
- **WARNING!** WHEN TRAVELING UP OR DOWN AN INCLINE, DRIVE YOUR POWER CHAIR SLOWLY TO ENSURE A SAFELY CONTROLLED ASCENT OR DESCENT



Warnings

- **WARNING!** No alterations or substitutions should be made to the power chair securement points or to the structural frame components without prior consent from your authorized provider.
- **WARNING!** Belt restraints must not be held away from the body by power chair components such as armrests or wheels.
- **WARNING!** Belt restraints should make full contact with the shoulder and chest and pelvic restraints should be positioned low across the front of the body near the junction of the thigh and pelvis.
- **WARNING!** The buckle of belt restraint systems should not be located near power chair components that may come in contact with the buckle release button in the event of a vehicle accident or collision.
- **WARNING!** The power chair should be inspected by a representative of the manufacturer before reuse following involvement in any type of vehicle collision.
- **WARNING!** For your safety, please read the owner's manual before operating this product. Before reading through the owner's manual, please do not operate the product.
- **WARNING!** For your safety, when you operate the product or before you operate the product, if you find any problem, please stop operating the product immediately and contact with the dealer for solving the problem.
- **WARNING!** For your safety, the user should be comply with the following condition for operating the product:
 1. Spirits in good condition, can clearly distinguish the surroundings condition and physical function are normal to operate the scooter.
 2. After drinking or eating of alcoholic beverages or food, do not operate the product.
 3. Before operating the scooter, do not take medicine which might affect sanity or mental state.
- **WARNING!** For your own safety, Visually Impaired person do not operate this product.
- **WARNING!** Do not operate the product with depleted batteries since the occupant could be stranded.
- **WARNING!** If component of the product surface (such as shroud, seat, armrest, joystick handles, etc.) exposures to the sun, this may cause high temperature on the part surface, the high temperatures may cause dangers. Please use the product, when the surface is cool down.



Warnings

- **DO NOT** use an escalator to move a wheelchair between floors. Serious bodily injury may occur.
- **DO NOT** lean over the top of the back upholstery to reach objects from behind as this may cause the wheelchair to tip over.
- **DO NOT** shift your weight or sitting position toward the direction you are reaching as the wheelchair may tip over backwards or sideways.
- **DO NOT** tip or wheel the wheelchair without assistance, unless you are highly skilled.
- **DO NOT** attempt to stop a moving wheelchair with wheel locks. Wheel locks are not brakes.
- **DO NOT** stand on the frame of the wheelchair.
- **ALWAYS** use caution when transferring in or out of the wheelchair. Every precaution should be taken to reduce the transfer distance. Also be certain the wheel locks are engaged to prevent the wheels from moving.



Cautions

- Riding over curbs or obstacles can cause tipping and serious bodily harm. If you have any doubt that you can safely cross any curb or obstacle, **ALWAYS ASK FOR HELP**. Be aware of your riding skills and personal limitations. Develop new skills only with the help of a companion.
- The wheelchair is not designed for weight training and is unsafe for use a seat while weight training. Weight training from the wheelchair substantially changes the stability of the chair and may cause tipping.

■ EMC

This vehicle has an immunity level of 30 v/m which should protect it from Electromagnetic Interference(EMI) from radio wave sources. The rapid development of electronics, especially in the area of communications, has saturated our environment with electromagnetic (radio) waves that are emitted by television, radio and communication signals. These EM waves are invisible and their strength increases as one approaches the source. All electrical conductors act as antennas to the EM signals and, to varying degrees, all power wheelchairs and power scooters are susceptible to electromagnetic interference (EMI). This interference could result in abnormal, unintentional movement and/or erratic control of the vehicle.

Powered wheelchairs and electric power scooters (in this text, both will be referred to as powered wheelchairs) may be susceptible to electromagnetic interference (EMI), which is interfering electromagnetic energy emitted from sources such as radio stations, TV stations, amateur radio (HAM) transmitters, two-way radios and cellular phones. The interference (from radio wave sources) can cause the powered wheelchair to release its brakes, move by itself or move in unintended directions. It can also permanently damage the powered wheelchair's control system. The intensity of the EM energy can be measured in volts per meter(V/m). Each powered wheelchair can resist EMI up to a certain intensity. This is called the "immunity level." The higher the immunity level, the greater the protection. At this time, current technology is capable of providing at least 30 V/m of immunity level which would provide useful protection against common sources of radiated EMI.

Following the warnings listed below should reduce the chance of unintended brake release or powered wheelchair movement that could result in serious injury:

- 1) Do not turn on hand-held personal communication devices such as citizens band (CB) radios and cellular phones while the powered wheelchair is turned on.
- 2) Be aware of nearby transmitters such as radio or TV stations and try to avoid coming close to them.

- 3) If unintended movement or brake release occurs, turn the powered wheelchair off as soon as it is safe.
- 4) Be aware that adding accessories or components, or modifying the powered wheelchair, may make it more susceptible to interference from radio wave sources. (Note: there is no easy way to evaluate their effect on the overall immunity of the powered wheelchair).
- 5) Report all incidents of unintended movement or brake release to the powered wheelchair manufacturer, and note whether there is a radio wave source nearby.

Warning: The wheelchair might disturb the operation of devices in its environment that emit electromagnetic fields (e.g. alarm systems of shops, automatic doors)

TURN OFF YOUR POWER WHEELCHAIR AS SOON AS POSSIBLE WHEN EXPERIENCING ANY OF THE FOLLOWEING:

1. Unintentional motions.
2. Unintended or uncontrollable direction.
3. Unexpected brake release.

The FDA has written to the manufacturers of power wheelchairs, asking them to test their new products to be sure they provide a reasonable degree of immunity against EMI. The letter says that powered wheelchairs should have an immunity level of at least 30 V/m, which provide a reasonable degree of protection against the more common sources of EMI. The higher the level, the greater the protection.

■ Driving Outdoors

When you are on the road, please pay attention to the following:



NO!

Do not drive in traffic.



NO!

Do not drive beside a river, port, or lake without a fence or railing.



NO!

If possible, do not drive during the rain.



NO!

If possible, do not drive during or on snow.



NO!

Do not drive off-road or on any uneven surfaced roads.



NO!

If possible, do not drive at night.



DO!

Make sure that there are no obstacles behind you when in reverse.

We recommend to set up the speed at the lowest setting for reversing.



NO!

Do not make sudden stops, weave erratically, or make sharp turns.



DO!

Keep your arms on or inside the armrests and feet on the footrest at all times.



NO!

Do not attempt to climb curbs greater than $1\frac{1}{2}$ "(4cm).

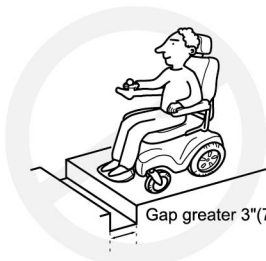

NO!

Do not attempt to cross over a gap greater than 3"(7.5cm).

Gap greater 3"(7.5cm)

■ Driving on Various Terrains

Driving on hills is more dangerous than on level surfaces. If you fail to heed these warnings, a fall, tip-over or loss of control may occur and cause severe injury to the vehicle user or others.



NO!

Do not attempt to climb a hill greater than 6°
(Refer to specification on page 17.)



NO!

Do not reverse while driving up a hill.

Forward only. If you reverse while moving up a hill, it may cause the vehicle to tip over.

(Refer to specification on page 17.)



NO!

Do not attempt to drive across a sloping surface greater than 3°

Driving across a slope greater than 3° is very dangerous and may cause the vehicle to tip over.



NO!

Do not drive over soft, uneven or unprotected surfaces such as grass, gravel and decks.

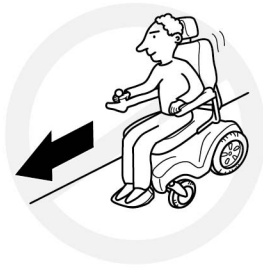

DO!

Use low speed while driving down hill.

When braking while moving down hill, the wheelchair will take longer to come to a complete stop.



NO!

Do not get on and off on a hill.

Always stop on the level surface to get in and get out of the vehicle.



YES!

Always climb or descend gradients perpendicular to the slope or ramp.

Owner's Manual

Familiarize yourself with your powerbase wheelchair

■ Feature Diagram

In this section, we will acquaint you with the many features of your powerbase wheelchair and how they work. Upon receipt of your powerbase wheelchair, inspect it for any damage. Your powerbase wheelchair consists of the following components.

P331 R-Series Positioning Seating System



■ Powerbase Wheelchair Specifications

Model No.	P331 (Rehab seat)
Length	90cm/35.6"
Width	69cm/27"
Seat Width	46cm~61cm/18"~24"
Seat Height (from ground)	45cm~47cm/17.6"~18.6"
Speed	8kph/5mph
Range up to	24.7km(15.3mi)
Weight Capacity	204kg/450lbs
Base Weight	57kg/126lbs
Seat Weight	40kg/88lbs
Battery Weight	17kg/34lbs
Motor	DC 24V, 200W(Rating)/575W(Max)
Brake	Intelligent, regenerative, electromagnetic brakes
Controller	P & G Controller VR2
Battery	55AH*2pcs
Charger	5A/6A/8A/10A Off-board
Gradient	6°(204kg/450lbs)
Caster Wheel	F:6" Tire / R:6" Tire
Drive Wheel	12" Tire
Recommended Storage and Shipping Temperature	Dry(15%~95% Non-Condensing), Well ventilated -20°C~60°C(-4°F~140°F) Without batteries

■ Terminology

Joystick: The device used to "move" the powerbase wheelchair.

Controller: The device that allow joysticks to function. Not all joysticks have a controller.

Armrests: Where arms can rest during time spent on powerbase wheelchair.

Footrest: Where feet rest during time spent on the powerbase wheelchair.

Drive Wheel: The wheels that move the powerbase wheelchair. These are the main wheels.

Caster Wheel: The front wheels and the rear wheels.

Controller Harness : Cable connecting the joystick to the controller.

Owner's Manual

Freewheel Lever: For convenience, your powerbase wheelchair is equipped with freewheel levers. These levers allow you to disengage the drive motors and maneuver the chair manually.

Type B applied parts: seat, armrest, foot plate, joystick module.

Classification: Internal powered equipment by 24 VDC, Class II in charging mode.

Mains connection of battery charger: 100-120 VAC, 50/60 Hz.

Braking information: 1) Running brake: Your electrical wheelchair is equipped with electromagnetic and regenerative brakes. Uses electricity to rapidly slow the wheelchair when the joystick return to the center/stop position and act as a parking brake.

2) Parking brake: when joystick on center position act a electromagnetic brake. In freewheel mode an assistant has to operate the parking brake by engaging the drive system again. No battery power is necessary for this function.



WARNING: DO NOT use the powerbase wheelchair without the presence of an attendant while the drive motors are disengaged! **DO NOT** disengage the drive motors when your powerbase wheelchair is on an incline, as the chair could roll down on its own, causing injury!

To engage or disengage the drive motors:

1. Turn the freewheel levers upward to disengage the drive motors.
2. Turn the freewheel levers downward on the front of the powerbase wheelchair to engage the drive motors.

Note: It is important to remember that when the powerbase wheelchair is in the freewheel mode, the braking system is disengaged.

■ Battery Removal:

- (1) Turn off the power to the controller.
- (2) Make sure that the power chair is in drive mode.
- (3) Remove the rear cover by squeezing the release handles. (Fig A1)
- (4) Lifting the rear cover up and away from the power base. (Fig A2)
- (5) Disconnect the quick release battery connectors. (Fig A3)
- (6) Remove the batteries. (Fig A4)



Fig A1



Fig A2



Fig A3



Fig A4

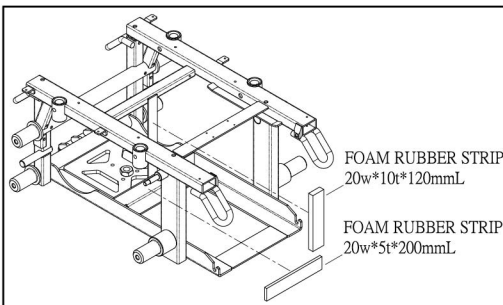

Fig A5

Due to different brands of battery in the market, the size of batteries may vary. Please use Foam Rubber Strip in the box to secure the batteries in case of loosen or shaking.(Fig A5)

■ Manual Freewheel Levers:

The powerbase wheelchair has a manual freewheel lever on each parking brake. Manual freewheel levers enable you to disengage parking brake and maneuver the chair manually.



WARNING! Do not use the powerbase wheelchair while the drive motors are disengaged! Do not disengage the drive motors when the powerbase wheelchair is on an incline, as the unit could roll on its own, causing injury!

To engage or disengage the drive motors:

1. Locate the lever in front of each motor.
2. Push the two levers down ward to engage the drive motors.(Fig B1)
3. Pull the two levers up ward to disengage the drive motors.(Fig B2)

If a lever is difficult to move in either direction, slightly rock the powerbase wheelchair back and forth. The lever should then move to the desired position.



WARNING! It is important to remember that when your powerbase wheelchair is in freewheel mode, the braking system is disengaged.

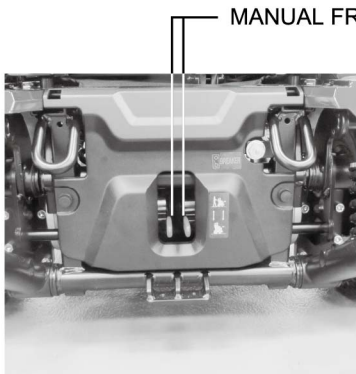

Fig B1. Drive Mode (Drive Engaged)

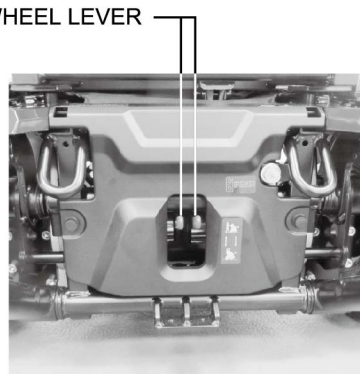

Fig B2. Freewheel Mode (Drive disengaged)

■ Batteries and Charging

Your Power Wheelchair uses two long-lasting, 12-volt batteries. These batteries are sealed, maintenance free, deep-cycle batteries. Since they are sealed, there is no need to check the electrolyte (fluid) level. Deep-cycle batteries are designed to handle a deep discharge. Though they are similar in appearance to automotive batteries, they are not interchangeable. Automotive batteries are not designed to handle a long, deep discharge, and are also unsafe for use in power wheelchairs.

WARNING! Battery posts, terminals and related accessories contain lead and lead compounds. Wash hands after handling.

BATTERY BREAK-IN

To break in your power wheelchair new batteries for maximum efficiency:

1. Fully recharge any new battery prior to initial use. This will bring the battery up to about 90% of its peak performance level.
2. Run your power wheelchair about the house. Move slowly at first, and do not stray too far until you become accustomed to the controls and break in the batteries.
3. Give the batteries another full charge of 8 to 14 hours and operate the power wheelchair again. The batteries should now perform at over 90% of their potential.
4. After four or five charging cycles, the batteries will top off at 100% charge and last for an extended period.

IMPORTANT INFORMATION ABOUT BATTERIES

A fully charged deep-cycle battery provides reliable performance and extended battery life. Keep your batteries fully charged whenever possible. Batteries that are regularly discharged, infrequently charged, or stored without a full charge may be permanently damaged, causing unreliable operation and limited battery life.

If you do not use your power wheelchair regularly, we recommend maintaining battery vitality by charging the batteries at least once a week.

WARNING! Use only the original battery charger, which was accompanied with your power wheelchair.

Note: If you are storing a power wheelchair for an extended period of time, you may wish to block the unit up off the ground with several boards under the frame. This keeps the tires off the ground to prevent the possibility of flat spots developing.

If you intend to use public transportation while using your power wheelchair, you must contact in advance the transportation provider to determine their specific requirements.

Sealed Lead Acid and Gel Cell batteries are designed for application in wheelchairs and in other mobility vehicles. Generally, Sealed Lead Acid batteries that are marked as "Non-Spill" are safe for all forms of transportation such as aircraft, buses, and trains. We suggest that you contact your transportation provider to determine specific requirements of transportation and packaging.

If you wish to use a freight company to ship the power wheelchair to your final destination, repack the power wheelchair in the original shipping container and ship its batteries in separate boxes.

Charging Your Batteries

The battery charger is one of the most important parts of your power wheelchair. Optimize your power wheelchair performance by charging the batteries safely, quickly, and easily. Use only the charger supplied with the vehicle.

Charging Procedures

1. Keep charger output plug inserted into the charging socket in the front of the controller before having the charger input plugged into an electrical outlet.
2. Follow the instructions on the front panel of the charger for operating and learn the meanings of the different indicators accordingly.
3. Minimum charging time varies depending on battery condition and discharge level. It is recommended to charge the batteries overnight.

NOTE: The specially designed charger assures that excess power is not consumed regardless of how long it is switched on, and connected to the batteries.

4. Once charging is complete, disconnect the charger from the electrical outlet and then disconnect the charger from the controller socket. Do not leave the charger connected to controller when input power is disconnected. It is dangerous and will jeopardize the power charging to the batteries.

CARE AND MAINTENANCE

Your powerbase wheelchair requires a minimal amount of care and maintenance. If you do not feel confident in your ability to perform the maintenance listed below, you may schedule inspection and maintenance at your authorized. The following areas require periodic inspection and/or care and maintenance.

Tire pressure

- If equipped with pneumatic tires, always maintain the psi/bar/kPa air pressure indicated on each tire.
- It is important that the psi/bar/kPa air pressure indicated on each tire be maintained in pneumatic tires at all times. Do not underinflate or overinflate your tires.
- Low pressure may result in loss of control, and overinflated tires may burst. Failure to maintain the psi/bar/kPa air pressure indicated on pneumatic tires at all times may result in tire and/or wheel failure.
- Regularly inspect your scooter's tires for signs of wear.
- Tire pressure: Pneumatic tires, there should be 2.1-2.4 bar (206.9-241.3kPa / 30-35 psi) in each tire. Pressure (max.) = 3.5 bar max. (344.8kPa / 50psi).

Exterior surfaces

Main Shroud, rear shroud, and tires can benefit from an occasional application of rubber or vinyl conditioner.

Do not use a rubber or vinyl conditioner on the powerbase wheelchair's vinyl seat or tire tread, as this may cause them to become dangerously slippery.

Cleaning and disinfection

- Use a damp cloth and mild, non-abrasive cleanser to clean the plastic and metal parts of your powerbase wheelchair.

Avoid using products that may scratch the surface of your powerbase wheelchair.

- If necessary, clean your product with an approved disinfectant. Make sure the disinfectant is safe for use on your product before application.
- Follow all safety instructions for the proper use of the disinfectant and cleaning agent before applying it to your product. Failure to comply may result in skin irritation or premature deterioration of upholstery and/or scooter finishes.

Battery terminal connections

- Make certain that the terminal connections remain tight and uncorroded.
- The batteries must sit flat in the battery wells.

ABS plastic shrouds

- The fender LH/RH are formed from durable ABS plastic and are coated with an advanced formula urethane paint.
- A light application of car wax will help the shrouds retain their high gloss.

Motor brushes

The motor brushes are housed inside of the motor transaxle/assembly. They should be inspected periodically for wear by your authorized dealer.

AXLE BEARINGS AND THE MOTOR/TRANSAXLE ASSEMBLY

You do not need to lubricate these items, as they are all prefabricated and sealed.

DAILY CHECKS

- With the controller turned off, check the joystick. Make sure it is not bent or damaged and that it returns to center when you release it. Check the rubber boot around the base of the joystick for damage. Visually inspect the boot only. Do not handle or try to repair it. See your authorized service center if there is a problem.
- Visually inspect the controller harnesses. Make sure that they are not frayed, cut or have any wire exposed. See your authorized provider if there is a problem with any of these harnesses.

WEEKLY CHECKS

- Disconnect and inspect the controller and charger harnesses from the electronics connector housing. Look for corrosion. Contact your local provider if necessary.
- Ensure that all parts of the controller system are securely fastened to your powerbase wheelchair. Do not over tighten any screw.
- Check for proper tire inflation, there should be 30-35psi in each tire. If a tire will not hold air, replace the tube.
- Calibrate the joystick if a noticeable difference in performance is detected or if the joystick does not operate properly.
- Check the brakes. This test should be carried out on a level surface with at least three feet of clearance around your powerbase wheelchair.

To check the brakes:

1. Turn on the controller and turn down the speed response adjustment knob.
2. After one second, check the battery gauge. Make sure that it remains on.
3. Slowly push the joystick forward until you hear the electric brakes click.

Note: The powerbase wheelchair may move when performing this test. Immediately release the joystick. You must be able to hear each electrical brake operating within a few seconds of joystick movement.

MONTHLY CHECKS

- Check that the anti-tip wheels do not rub the ground when you are operating the powerbase wheelchair; adjust them as necessary.
- Check for extreme wear on the anti-tip wheels. Replace them as necessary.
- Check for drive tire wear. See an authorized provider for repair.
- Check the front/rear castors for wear. Replace as necessary.
- Check the front/rear forks for damage or fluttering which indicates that they may need to be adjusted or the bearings may need to be replaced. See an authorized provider for repair.
- Keep your powerbase wheelchair clean and free of foreign material such as hair, food, drink, etc.

YEARLY CHECKS

- Take your powerbase wheelchair to an authorized provider for yearly maintenance. This helps to ensure that your powerbase wheelchair is functioning properly and helps prevent future complications.

Wheel replacement

If your powerbase wheelchair is equipped with pneumatic tires and you have a flat tire, you can have the tube replaced.

If your powerbase wheelchair is equipped with a solid tire insert, either the solid insert or the entire wheel must be replaced depending on the model. Contact your dealer for information regarding replacement wheels for your powerbase wheelchair.

Be sure that the powerbase wheelchair is powered off and the powerbase wheelchair is not in freewheel mode before performing this procedure.

Follow these easy steps for a quick and safe repair for solid tires:

1. Push the ON/Off switch button to turn off the power.
2. Elevate the side of the powerbase wheelchair of which you are removing the tire. Place wooden blocks under the frame to elevate the powerbase wheelchair.
3. Remove the drive wheel nut and washer from the axle.
4. Pull the wheel off the axle.
5. Slide the new wheel back onto the axle. Make sure that the axle key is in the axle slot. Failure to ensure that the axle key is properly installed into the axle slot when mounting the wheel can result in electronic brake failure, personal injury, and product damage.
6. Reinstall the drive wheel nut and washer onto the axle and tighten. Make sure both the nut and washer are reinstalled and tightened properly.
7. Remove the block from beneath the powerbase wheelchair.

Wiring harnesses

- Regularly check all wiring connections.
- Regularly check all wiring insulation, including the charger power cord, for wear or damage.
- Have your authorized dealer repair or replace any damaged connector, connection, or insulation that you find before using your powerbase wheelchair again.
- Even though the powerbase wheelchair has passed the necessary testing requirements for ingress of liquids, you should keep electrical connections away from sources of dampness, including direct exposure to water or bodily fluids and incontinence. Check electrical components frequently for signs of corrosion and replace as necessary.

Nylon lock nut replacement

Any nylon insert lock nut removed during the periodic maintenance, assembly, or disassembly of the scooter must be replaced with a new nut. Nylon insert lock nuts should not be reused as it may cause damage to the nylon insert, resulting in a less secure fit. Replacement nylon insert lock nuts are available at local hardware stores or through your dealer.

Console, charger, and electronic controller module

- Keep these areas away from moisture.
- Before operating your powerbase wheelchair, allow any of these areas to dry thoroughly if they have been exposed to moisture.

Fuses

To replace a fuse:

1. Remove the fuse by pulling it straight out of its slot.
2. Examine the fuse to be sure it is blown.
3. Insert a new fuse of the proper rating.

Storing your powerbase wheelchair

If you plan on not using your powerbase wheelchair for an extended period of time, it is best to:

1. Fully charge its batteries prior to storage.
2. Disconnect the batteries from the powerbase wheelchair.
3. Store your powerbase wheelchair in a warm, dry environment.
4. Avoid storing your powerbase wheelchair where it will be exposed to temperature extremes.

Always protect batteries from freezing temperatures and never charge a frozen battery. Charging a frozen battery can result in damage to the battery.





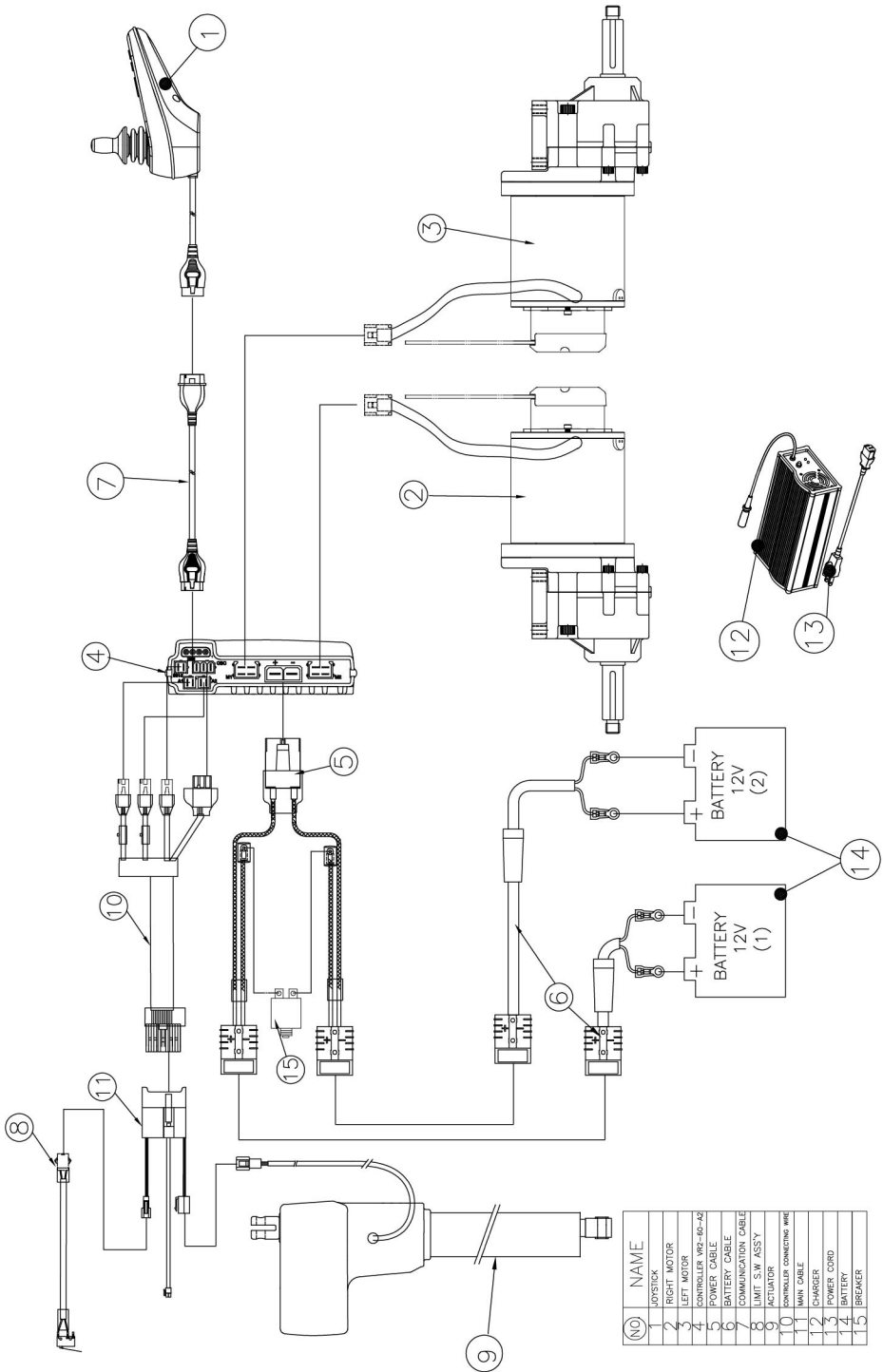



Recycle

Information on the recycling of used batteries and other parts of the powerbase wheelchair; use only special recycling for the powerbase wheelchair parts, no general disposal (e.g. batteries, electronics)



(NO)	NAME
1	JOYSTICK
2	RIGHT MOTOR
3	LEFT MOTOR
4	CONTROLLER (VR2-80-A2)
5	POWER CABLE
6	BATTERY CABLE
7	HORN/CHARGER CABLE
8	HORN/CHARGER ASSY
9	ACTUATOR
10	CONTROLLER CONNECTING WIRE
11	MAIN CABLE
12	CHARGER
13	POWER CORD
14	BATTERY
15	BREAKER

IEC Symbols

	Direct current
IPX4	Protect against splashing water
	Attention, consult accompanying document.
	ON/ OFF Button on the controller
5A/24V	Use DC 24V/5A charger
	Follow the instructions for use
	Type B applied part
	Class II Equipment
	Not intended for use as seat in a motor vehicle
	Pinch/Crush points created during assembly
	Do not stand on the footplate

WARNING! Always drive straight up or straight down an incline, ramp, or slope to reduce the possibility of a tip or a fall.

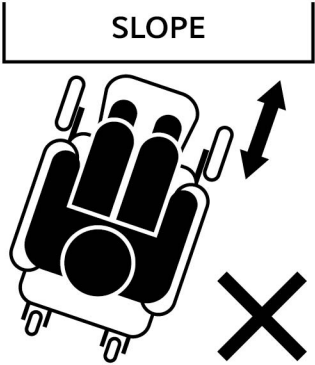
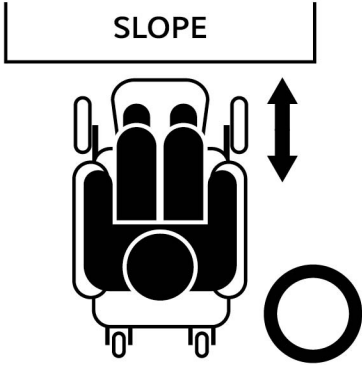



Figure 1



Figure 2

TROUBLESHOOTING TIPS

If your power chair or scooter is not operating properly, please take the following steps prior to calling Technical Support.

Load-test Batteries—See Figure 1

1. Attach Battery Load-tester to battery.
Observe polarity: Red is Positive—Black is Negative
2. Hold load switch on for 10 seconds. A good reading is 11.2 Volts DC, or in the Green.

Note: A Voltmeter cannot load-test batteries.

Test Voltage—See Figure 2

Utilizing a Voltmeter, place meter leads in charging port. The voltage reading should be 25 Volts DC, plus or minus 2 volts.

Note: Batteries are connected in series.

If the above tests are successful, proceed with the following test.

1. For power chairs, place gearbox levers in Freewheel.
2. Turn on controller and run in all four quadrants.
3. If troubleshooting a scooter, elevate rear wheels and run in Forward and Reverse.

If any of the above tests fail, contact your local dealer.

Disclosure information(ISO 7176-15:1996)					
	min.	max.		min.	max.
Overall length with legrest	--	1150mm	Seat plane angle	--	0°
Overall width	--	690mm	Effective seat depth(M)	--	510mm
Folded length	--	--	Effective seat width	--	610mm
Folded height	--	--	Seat surface height at front edge	--	690mm
Total mass	--	137kg	Backrest angle		20°
Mass of the heaviest part	--	17/40kg Battery/seat	Backrest Height		570mm
Static stability downhill	--	9°	Footrest to seat distance	--	310mm
Static stability uphill	--	9°	Leg to seat angle	--	90°
Static stability sideways	--	9°	Armrest to seat distance	--	200mm
Energy consumption	--	32km	Front location of armrest structure	--	--
Dynamic stability uphill	--	6°	Handrim diameter	-	-
Obstacle climbing	--	40mm	Horizontal location of axle	70mm	165mm
Maximum speed forward	--	8km/h	Minimum turning radius	700mm	--
Minimum horizontal braking distance from max speed	--	1500mm	Minimum turn-around width	1230mm	--

WARNING! The brake distance at the slope might be longer than the minimum brake distance under maximum speed.



MERITS HEALTH PRODUCTS, INC.

4245 EVANS AVENUE | FORT MYERS FL 33901 | 239-772-0579
www.meritsusa.com